

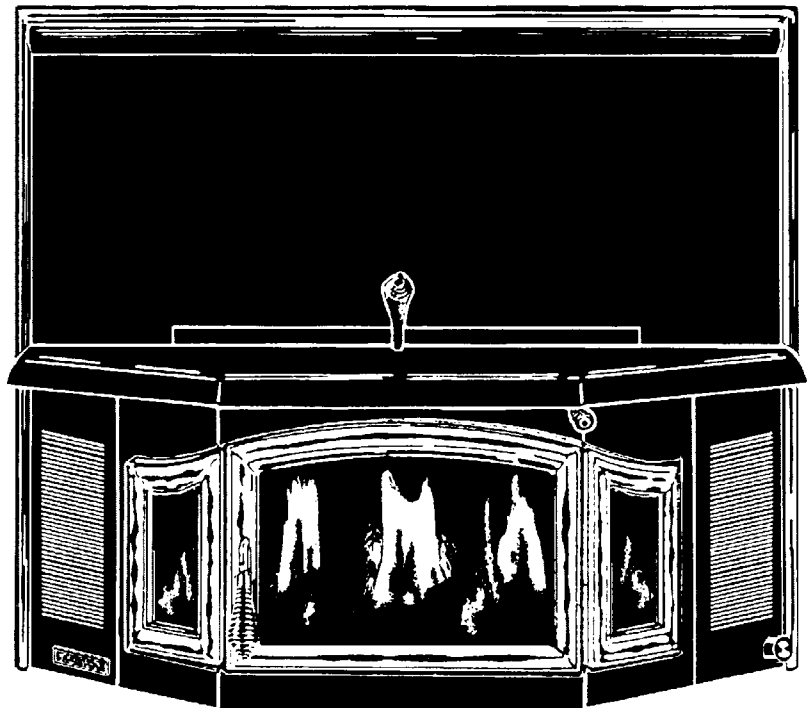

INSTALLATION AND OPERATION MANUAL

EPA CERTIFIED
CATALYTIC WOOD
BURNING FIREPLACE
INSERT



www.nficertified.org

We suggest that our wood-burning hearth products be installed and serviced by professionals who are certified in the U.S. by the National Fireplace Institute® (NFI) as NFI Woodburning Specialists or who are certified in Canada by Wood Energy Technical Training (WETT).



Wood Energy
Technical Training
www.wettinc.ca

RETAIN THESE
INSTRUCTIONS
FOR FUTURE
REFERENCE

MODEL BV400C-2

THIS APPLIANCE MUST BE INSTALLED BY A QUALIFIED INSTALLER.
READ ENTIRE MANUAL THOROUGHLY BEFORE INSTALLATION.

Tested &
Listed By  Beaverton
Oregon USA
OMNI-Test Laboratories, Inc.

P/N 775,005M Rev. M, 12/03

IMPORTANT WARNINGS

CAUTION: PLEASE READ THIS ENTIRE MANUAL BEFORE YOU INSTALL AND USE YOUR NEW ROOM HEATER. FOR YOUR SAFETY, FOLLOW THE INSTALLATION, OPERATION AND MAINTENANCE INSTRUCTIONS EXACTLY, WITHOUT DEVIATION. FAILURE TO FOLLOW THESE INSTRUCTIONS MAY RESULT IN PROPERTY DAMAGE, BODILY INJURY, OR EVEN DEATH. IF THIS APPLIANCE IS NOT PROPERLY INSTALLED, A HOUSE FIRE MAY RESULT. CONTACT YOUR LOCAL BUILDING OR FIRE OFFICIALS ABOUT RESTRICTIONS AND INSTALLATION INSPECTION REQUIREMENTS IN YOUR AREA.

1. If utilizing an older chimney, it must be inspected for adequate serviceability. Refer to the heading *Chimney Inspection* on page 4.
2. Install only in masonry fireplaces, built to UBC 37 or ULC S628 standards or A factory built fireplace built to UL 127 or ULC S610 standards.
3. The minimum clearances must be maintained for all combustible surfaces and materials including; furniture, carpet, drapes, clothing, wood, papers, etc. Do not store firewood within this clearance space.
4. This appliance requires a non-combustible fireplace hearth or hearth extension (see *Floor Protection* on page 4 for additional information).
5. Minimum ceiling height must be 7 feet (213 cm) (measured from base of appliance to ceiling).
6. **DO NOT CONNECT THIS UNIT TO A CHIMNEY FLUE CONNECTED TO ANOTHER APPLIANCE.**
7. Do not connect this appliance to air ducts or any air distribution system.
8. Do not install appliance in a sleeping room.
9. **PREVENT CREOSOTE FIRE:** Inspect and clean chimney frequently. Under certain conditions of use, creosote buildup may occur rapidly. Inspect chimney connector and chimney twice monthly and clean if necessary. Using green or inadequately seasoned wood can greatly increase creosote buildup. Use dry wood to minimize creosote buildup.
10. **USE SOLID WOOD FUEL ONLY:** This appliance is approved for burning dry seasoned natural wood only. **CAUTION: BURN UNTREATED WOOD ONLY. DO NOT BURN GARBAGE OR FLAMMABLE FLUIDS SUCH AS GASOLINE, NAPHTHA OR ENGINE OIL.**
11. Never use gasoline, gasoline-type lantern fuel, kerosene, charcoal lighter fluid, or similar liquids to start or "freshen up" a fire in this heater. Keep all such liquids well away from the heater while it is in use.
12. **DO NOT OVERFIRE:** If heater or chimney connector glows, you are overfiring. Overfiring this appliance could cause a house fire. Overfiring is a condition where the appliance is operated at temperatures above its design capabilities (see *Overfiring*, on page 19). Overfiring can be caused by improper installation, improper operation, lack of maintenance or improper fuel usage. Damage caused from overfiring is NOT covered under the manufacturers limited warranty (see *Care and Operation*, pages 12 to 14).
13. **NEVER LEAVE AN UNATTENDED FIREPLACE INSERT BURNING ON HIGH.** Operation of the fireplace insert with the primary air control at its highest burn rate setting for extended periods can cause dangerous overfiring conditions. The primary air control should only be positioned at the highest setting during start-up procedures and for short durations. When leaving the fireplace insert unattended ensure that the primary air control is set to the low or medium low range.
14. Use a metal container with a tight fitting lid to dispose of ashes.
15. **IN THE EVENT OF A COMPONENT FAILURE, USE ONLY COMPONENTS PROVIDED BY THE MANUFACTURER AS REPLACEMENT PARTS.**
16. Burning any kind of fuel uses oxygen from the dwelling. Be sure that you allow an adequate source of fresh air into the room where the fireplace insert is operating (see *Ventilation* on page 5).
17. **CAUTION: HOT WHILE IN OPERATION.** An appliance hot enough to warm your home can severely burn anyone touching it. Keep children, clothing and furniture away. Contact may cause skin burns. Do not let children touch the appliance. Train them to stay a safe distance from the unit.
18. Build fires directly upon the brick hearth inside the fireplace insert. Do not use grates, irons or any other method to elevate the fire.
19. Once the fire is established, never burn the appliance with the bypass damper open, except when refueling the appliance.
20. **CATALYTIC COMBUSTOR:** Do not operate this appliance without the catalytic combustor assembly (this consists of ceramics, gasket and a housing) properly installed. Burning of metal foils, coal, plastic garbage, diesel oil and sulfur will make the catalyst in the combustor inactive. The combustor is fragile; handle carefully. The performance of the catalytic device or its durability has not been evaluated as part of the certification.
21. See the listing label located on the back of fireplace (or see *Safety/Listing Label* on page 25).
22. **SAVE THESE INSTRUCTIONS.**

TABLE OF CONTENTS

Important Warnings	2
Testing/Listing, EPA, Using this Manual.....	3
Planning Your Installation	4-6
Installation	7-10
Product Features and Controls	11
Care and Operation	12-14
Recommended Fuel	15
Maintenance	15-17
Troubleshooting	18-19
Specifications.....	20
Replacement Parts List.....	21-23
Optional Accessories	24
Safety/Listing Label.....	25
EPA Label.....	26
Service / Maintenance Log	27

TESTING/LISTING

Model BV400C-2 has been tested to UL Standards; UL1482 for installation into residential applications. The listing laboratory is OMNI Test Laboratories, Inc.; Beaverton, Oregon; Report # SS-094-7.

EPA CERTIFICATION

This fireplace insert has been tested to rigorous emissions standard, and has been certified by the Environmental Protection Agency.

PACKAGING LIST

This appliance is packaged with an accessory package, which contains the following:

- One - Installation and operation instructions manual.
- One - Warranty
- One - Catalytic combustor temperature probe and sleeve.
- One - Damper hook
- One - Skid plate.
- One - 48" x 32" Surround Kit.

USING THIS MANUAL

Please read and carefully follow all of the instructions found in this manual. Please pay special attention to the safety instructions provided in this manual. The Homeowner's Care and Operation Instructions included here will assure you have many years of dependable and enjoyable service from your appliance.

CONGRATULATIONS ON THE PURCHASE OF YOUR NEW WOOD BURNING FIREPLACE INSERT MANUFACTURED BY LENNOX HEARTH PRODUCTS.

When you purchased your new insert, you joined the ranks of thousands of concerned individuals whose answer to their home heating needs reflects their concern for aesthetics, efficiency and our environment. We extend our continued support to help you achieve the maximum benefit and enjoyment available from your new insert.

It is our goal at Lennox Hearth Products to provide you, our valued customer, with an appliance that will ensure you years of trouble free warmth and pleasure.

Thank you for selecting a Lennox Hearth Products stove as the answer to your home heating needs.

Sincerely,
All of us at Lennox Hearth Products

PLANNING YOUR INSTALLATION

QUESTIONS TO ASK LOCAL BUILDING OFFICIAL

A correct installation is critical and imperative for reducing fire hazards and perilous conditions that can arise when wood burning appliances are improperly installed. The installer must follow all of the manufacturers' instructions.

The installation of a wood burning appliance must conform to local codes and applicable state and federal requirements. Familiarity with these requirements before installation is essential. Important considerations to discuss with local building officials include:

1. Applicable codes (i.e. Uniform Mechanical Code, State or Regional Codes.)

Electrical codes: The blower system has a flexible electrical cord that must be electrically grounded per local codes or per electrical codes:

In USA, NEC, ANSI/NFPA 70-2002.

In Canada, CSA C22.1

WARNING: ELECTRICAL GROUNDING INSTRUCTIONS: THIS APPLIANCE IS EQUIPPED WITH A THREE-PRONG (GROUNDING) PLUG FOR YOUR PROTECTION AGAINST SHOCK HAZARD AND SHOULD BE PLUGGED DIRECTLY INTO A PROPERLY GROUNDED THREE-PRONG RECEPTACLE. DO NOT CUT OR REMOVE THE GROUNDING PRONG FROM THIS PLUG. DO NOT ROUTE POWER CORD UNDER OR IN FRONT OF APPLIANCE.

2. Local amendments?
3. Is a permit required - cost?
(You may wish to contact your insurance company to ask if they require this).
4. Rooms where the installation is not allowed?

SMOKE DETECTORS

Since there are always several potential sources of fire in any home, we recommend installing smoke detectors. If possible, install the smoke detector in a hallway adjacent to the room (to reduce the possibility of occasional false activation from the heat produced by the fireplace insert). If your local code requires a smoke detector be installed within the same room, you must follow the requirements of your local code. Check with your local building department for requirements in your area.

IMPORTANT – THIS APPLIANCE IS NOT APPROVED FOR INSTALLATION INTO A MANUFACTURED (MOBILE) HOME.

FLOOR PROTECTION

This appliance requires a heat resistant non-combustible approved fireplace hearth or hearth extension. If a hearth extension is used it must be a 3/8" (minimum) noncombustible material or equivalent. If the floor protection is to be stone, tile, brick, etc., it must be mortared or grouted to form a continuous non-combustible.

This protected area must extend a minimum of 18" to the front of the fuel door opening and 8" beyond both sides of the fuel door opening

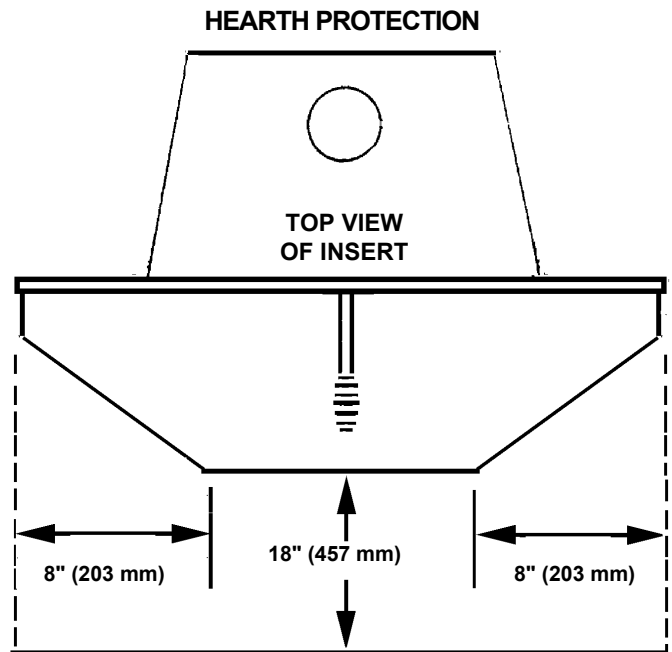

CHIMNEY INSPECTION

The existing fireplace should be inspected by a local fire marshal or qualified installer for adequate serviceability prior to installing this appliance.

Factory built fireplace: If any portion of the chimney system shows signs of structural or mechanical weaknesses, such as: cracks, leaky joints, corroded or warped surfaces. Look for obvious bulges in the lining, which may indicate the need to replace that section (use a bright flashlight. Any faulty portion must be repaired or replaced prior to installing this appliance. Also, inspect the attic to see that the chimney has proper clearance to combustible framing members.

Masonry fireplace: The chimney should have no cracks, loose mortar, other signs of deterioration, or blockage. Any necessary repairs should be done by a qualified mason.

If the existing fireplace flue system is dirty or has some obstruction in it, clean it. A dirty chimney can cause your insert to smoke when refueling, and can result in a chimney fire. An oversized chimney may result in less than optimum performance. Installations into a large masonry chimney may require a liner to improve performance.

PLANNING YOUR INSTALLATION

CLEARANCES

WARNING: IT IS VERY IMPORTANT THAT YOU OBSERVE THE MINIMUM CLEARANCES. DO NOT STORE FIREWOOD WITHIN THIS CLEARANCE SPACE. FAILURE TO MAINTAIN CLEARANCES TO ALL COMBUSTIBLES MAY RESULT IN A HOUSE FIRE.

There are listed clearances for your fireplace insert which were determined in a Laboratory testing and must be maintained.

Minimum Clearance to Combustibles

Stove top to mantel:	31" / 787 mm
Stove top to trim:	9" / 229 mm
Stove side to trim:	1" / 25 mm
Stove side to sidewall:	9" / 229 mm

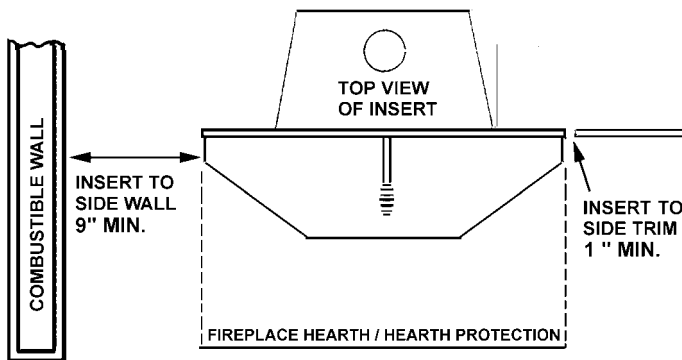

RAISED HEARTH

Note: Using a heat deflector on the surround, does not reduce clearances.

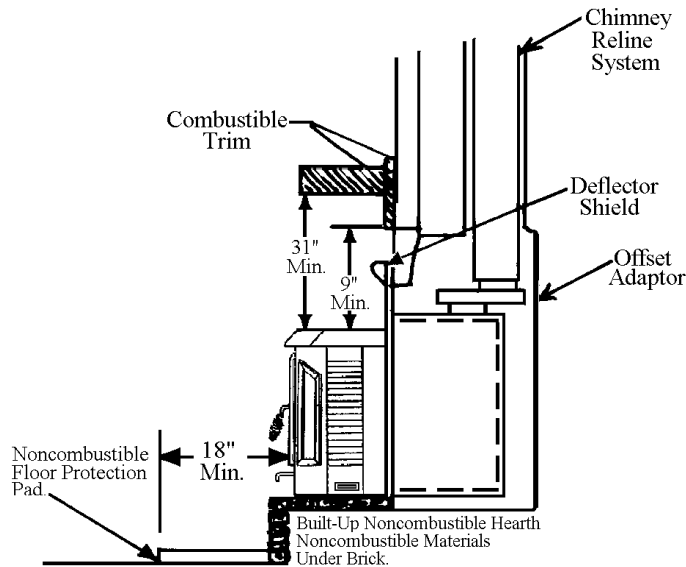

Raised Firebox

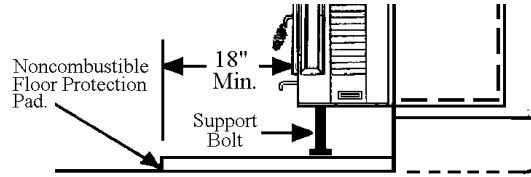

DRAFT REQUIREMENTS

The appliance is merely one component of a larger system. The other equally important component is the venting system. This is necessary for achieving the required flow of combustion air to the fire chamber and for safely removing unwanted combustion byproducts from the appliance. If the venting system's design does not promote these ends, the system may not function properly. Poorly functioning venting systems may create performance problems as well as be a safety hazard (i.e. an oversized chimney may result in less than optimum performance). Installations into a large, masonry chimney may require a liner to improve performance). A draft test should read between .05" W.C. (inches water column) and .07" W.C.

American National Standards Institute ANSI/NFPA 211-92, draft 1-7: A chimney or vent shall be so designed and constructed to develop a flow sufficient to completely remove all flue and vent gases to the outside atmosphere. The venting system shall satisfy the draft requirements of the connected appliance in accordance with the manufacturer's instructions.

PROVIDE ADEQUATE AIR FOR COMBUSTION

In well insulated and weather tight homes, it may be difficult to establish a good draft up your chimney. The poor draft is caused by a shortage of air in the house. To provide the needed air, crack a window on the windward side of the house.

VENTILATION REQUIREMENTS

THE FRESH AIR REQUIREMENTS OF THIS APPLIANCE MUST BE MET WITHIN THE SPACE WHERE IT WILL BE INSTALLED.

Ventilation is essential when using a solid fuel burning heater. The combustion process of this heater uses oxygen from inside the dwelling and it may be necessary to open a window or install a vent to provide make-up air into a dwelling that is well insulated (modern construction standards have resulted in homes that are highly energy-efficient and that allow little heat loss and air transfer). Other appliances in the dwelling also contribute to removing air from the dwelling (i.e. clothes dryers, exhaust fans, fireplaces, and other fuel burning appliances). If the available fresh air delivery in the dwelling is insufficient to support the demands of these appliances, problems can result (i.e. excessive negative pressure can develop in the dwelling which will affect the rate at which this appliance can draft. See *Draft Requirements* on this page).

PLANNING YOUR INSTALLATION

FACTORY BUILT FIREPLACES

This appliance is approved for installation into a listed factory built solid fuel burning fireplace. The fireplace firebox must accept the insert without modification other than removing bolted or screwed together pieces such as smoke shelf/deflectors, ash lips, screen or door tracks and damper assemblies, that must be reinstalled to restore the fireplace to its original operating condition if the insert is removed and not replaced. The removal of any part must not alter the integrity of the outer shell of the pre-engineered fireplace cabinet in any way.

Venting Requirements for factory built fireplace:

The fireplace damper must be secured in the open position. When installed into a Factory Built Fireplace this appliance requires the use of an 8" to 6" offset adapter. The offset adapter aligns the appliance flue outlet with fireplace flue and reduces flue outlet from 8" to 6" diameter (8 to 6" Offset Adapter, Cat. No. 14M79). If flue alignment is not necessary, a 8" to 6" bell reducer can be used in place of the offset adapter. The required vent is 6" diameter flex or rigid, UL1777 listed 2100° HT liner or equivalent. The liner must extend from the adapter at the flue outlet of the appliance to termination. Do not face seal over fireplace chimney cooling air systems.

WARNING: Do not substitute the heat rated 2100°HT liner with any other type line or a fire may result causing property damage, personal injury or loss of life.

MASONRY FIREPLACES

This appliance is approved for installation into a masonry fireplace built to UBC Chapter 37 standards. Do not remove brick or mortar from the masonry fireplace to accommodate this appliance.

Venting Requirements for masonry fireplace:

The fireplace damper must be secured in the open position. As a minimum, a flue extension past the fireplace header is required. A preferred installation is a positive flue connection (sealing the throat of the chimney). This appliance requires the use of a 6" or 8" diameter flex or rigid single wall pipe, minimum 24/25 MSG black or blued steel connector pipe (stainless steel recommended). Offsets can be handled with an offset adapter (it aligns starter pipe with fireplace flue). For more information on the offset adapters, see pages 8 and 24.

FIREPLACE CHIMNEY MAXIMUM SIZE TO ENSURE PROPER DRAFT (Applicable to Masonry Fireplace installations only).

The fireplace insert flue size is 8 inches in diameter, which is approximately 50 square inches, the minimum. The maximum flue size should be no more than (3) three times the cross sectional area of the size of the fireplace insert flue collar. In this case, that would be no larger than a 14 inch diameter stack (area = approx. 154 sq. inches). To calculate area for a square or rectangular flue, see below.

Note: Formulas for calculating Area:

Calculating area of a circle:

$$\pi \times r^2 = \text{Area} \quad (\pi = 3.1416, r = 1/2 \text{ diameter})$$

To calculate area of square or rectangle:

$$\text{Width} \times \text{Depth} = \text{Area}$$

Notes:

- It may be necessary to use a full-length liner to achieve adequate draft for the appliance. A draft gauge should .05" W.C., to .07" W.C. for optimum performance.
- This appliance is approved for all heatform style fireplaces (masonry fireplace with a metal fire-box liner).

INSTALLATION

FIREPLACE INSTALLATION

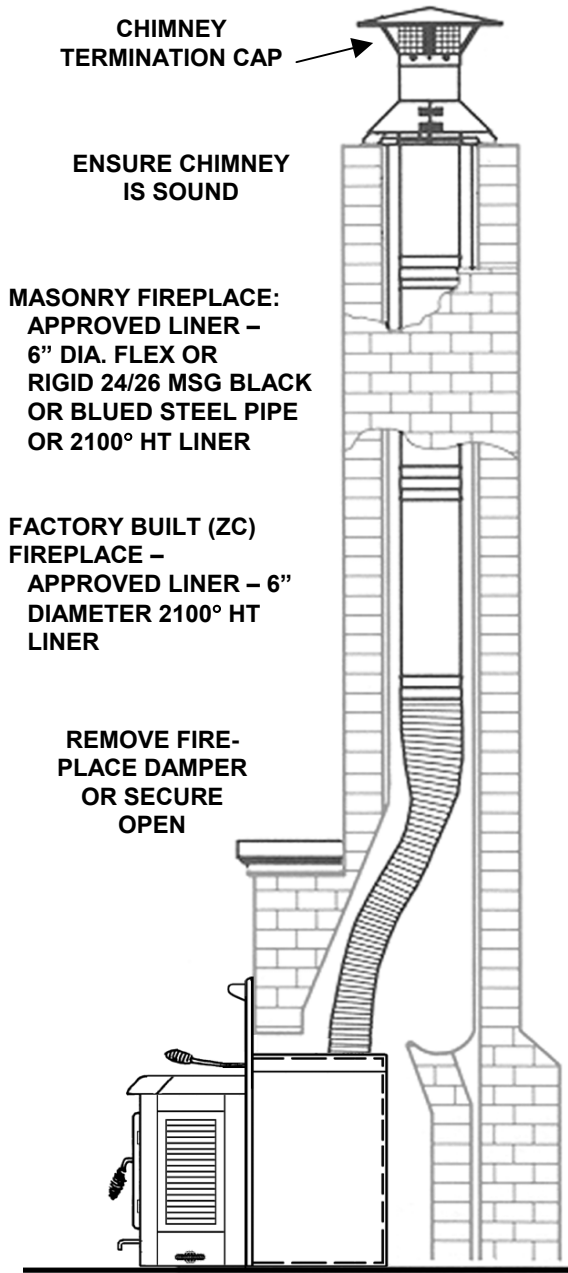

BV400C-2 MINIMUM FIREPLACE DIMENSIONS

Approximate minimum dimensions into fireplace:

Height: 20"
 Width: (front-29 3/4"), (rear-21 1/2")
 Depth: 15 3/4"

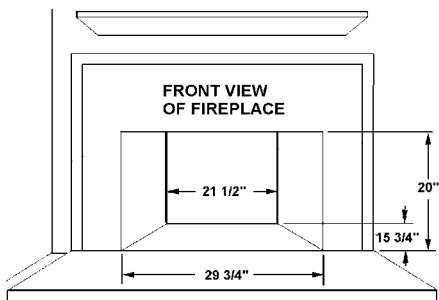

CATALYTIC TEMPERATURE PROBE

Install temperature probe prior to installing insert.

To install the *Catalytic Temperature Probe* locate the plug on the top, right-hand side of the bypass control rod. Remove the plug, install the sleeve, and place probe in sleeve. It may be necessary to bend the flange on the plug so it won't interfere with the probe temperature indicator.

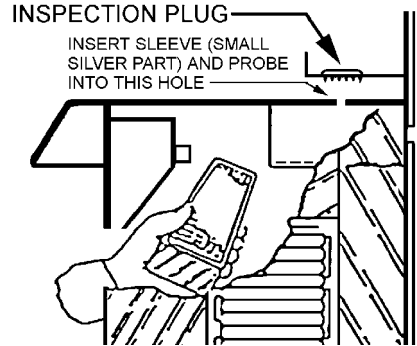

The Catalytic Temperature Probe is provided so you can monitor the temperature of your Catalytic Combustor. Once you have established a fire and the Catalytic Temperature Probe indicates the temperature of your Catalytic Combustor is between 500° - 600° F (approximately 20 - 25 minutes) close the Bypass Damper Control. Depending on the type and size of the fuel load as well as the length of time the stove has been burning, your Catalytic Combustor should operate between 1000 - 1800° F.

POWER CORD CHANGEOVER

DANGER: Risk of electrical shock. Disconnect power before servicing unit. Do not route power cord beneath heater.

To change the power cord from one side of insert to the other, perform the following steps:

1. Ensure power cord in NOT plugged in.
2. Remove the louver blower panels on each side of fuel door as follows. Each panel is held in place by two 1/4" head screws. Using a 1/4" socket or nut driver, remove the screws
3. Remove panels by pulling them outward slightly then forward.
4. Locate terminal block on right side of unit. Write down the locations where the black, white and green leads from the power cord are attached to the terminal block. Disconnect these three wires then reinstall them onto the terminal block on the left side of unit in the same corresponding positions (as you had written down).
5. Reinstall panels.

INSTALLATION

INSTALLATION STEPS

1. Remove all ashes from the fireplace.
2. Remove all materials inside the insert and set them aside.
3. Remove the surround panel (face shield) and attach insulation material provided using a nonflammable adhesive (i.e. RTV High Temperature Silicone).
4. Use a large piece of cardboard or other protective material and place it in front of the fireplace to protect floor or carpet during installation.
5. Remove the insert from its wood pallet by removing the screws.
6. Prepare chimney connection system as specified for masonry or zero clearance fireplaces.
7. Set the insert on the protective cardboard laid out in front of the fireplace centered in front of the fireplace opening.
8. (Masonry Fireplace) Slide insert into the fireplace far enough to attach the starter pipe or positive flue connection (a minimum of a 8" diameter starter pipe extending past the header is required). See * Note on page 9.
9. (Factory Built Fireplace) Slide insert into the fireplace far enough to attach connector to flue outlet. See * Note on page 9.
10. Offsets can be handled using an offset adaptor (it aligns starter pipe with flue. See *Offset Adapter*, page 24 for ordering information). Do not push insert in completely until surround assembly is installed. Care should be used to ensure that this adjustable connector is oriented so it does not angle downhill when positioned on the flue outlet on top of insert.

11. The floor of the fireplace is lower than the hearth, turn the adjusting bolt (located at the bottom of the groove in the rear of the insert firebox) clockwise until insert is level. An extension socket wrench will allow you to level the insert once it is completely installed by reaching over the top.
12. The skid plate (see following illustration) is provided for ease in completing the installation, and allows the insert to slide easily into the fireplace. Simply slip the skid plate under the adjustment (leveling) bolt, slightly lift the front of the insert, and push into place sliding along the skid plate

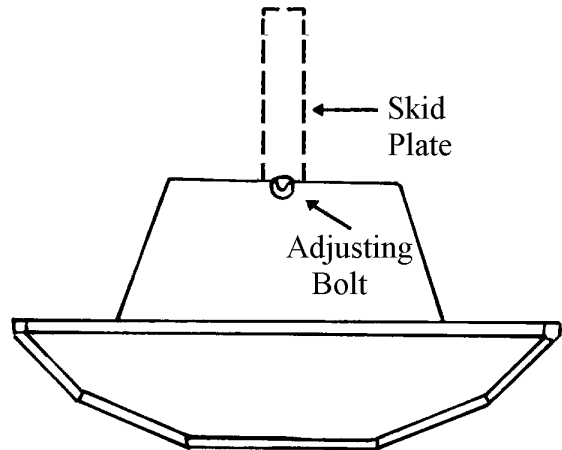

13. Reaching over the top of the insert, install the starter pipe in the stove flue outlet, or attach the positive flue connection to the insert. See * Note on page 9.

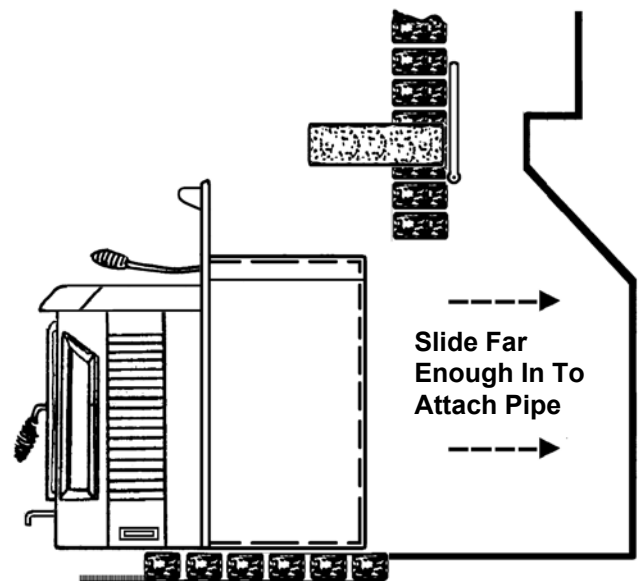
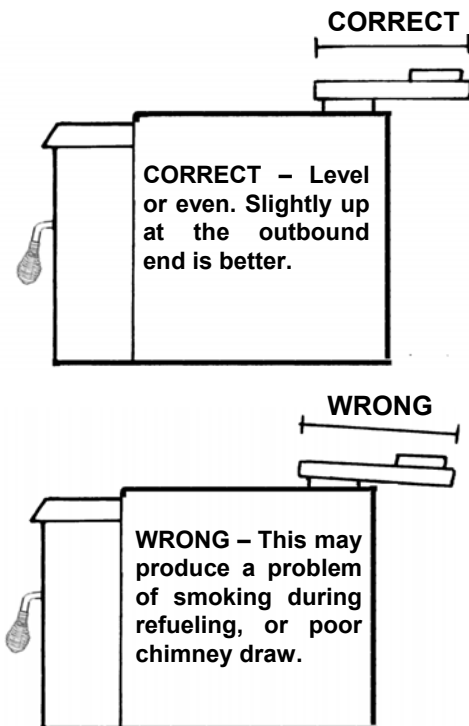

Offset Adaptors comes in two sizes. See page 24.

INSTALLATION

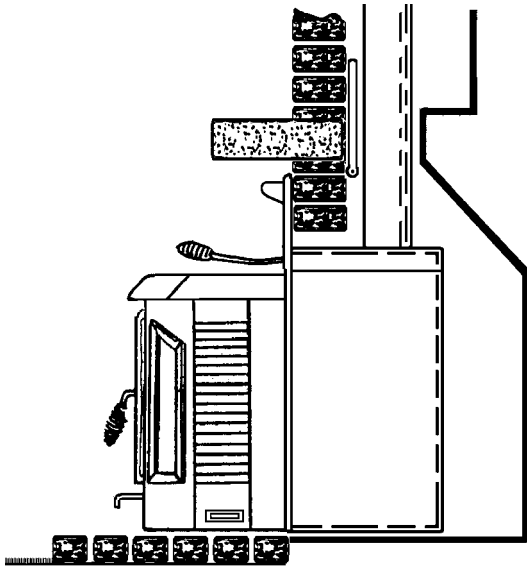

14. Push the insert to its desired position in the fireplace. The depth may vary as long as the starter pipe or other connecting pipe system can be effectively installed.

SURROUND ASSEMBLY

IMPORTANT: Do not face seal over chimney cooling air system on superior brand or any brand fireplace which is designed with the chimney cooling air system.

15. Pull the insert slightly forward to its desired position, and then attach the face shield using the surround clips and hardware as shown. Assemble the gold-tone trim, using the two sets of inside corner brackets. If there is a mantel above the fireplace opening, the heat deflector (provided) must be installed on the top edge of the surround panel (see following illustrations). Attach trim to the surround.

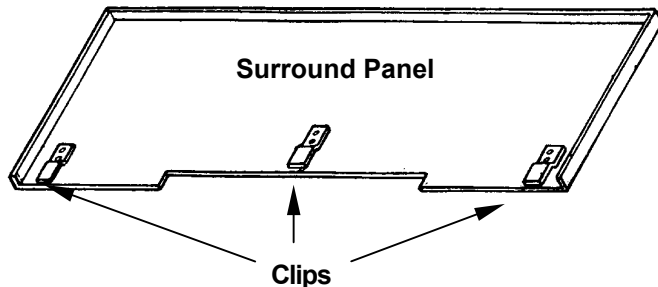

Heat Deflector Must Be Installed If There is a Mantel

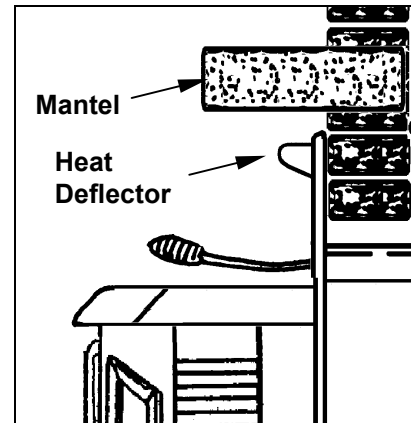

16. Push the insert back until surround panel insulation is compressed against the fireplace front, forming a tight seal. Test for air leaks by holding a candle around the edge of the surround to see if the smoke is pulled into the fireplace.

TEST FOR AIR LEAKS BY HOLDING A CANDLE AROUND EDGE OF FACE SHIELD TO SEE IF SMOKE IS PULLED INTO FIREPLACE.

* NOTE: Preferred method of attaching connector to flue outlet is to install two L-Brackets (1" angle bracket, 3/4" wide) on opposite sides of the flue outlet: Use self-tapping screws to secure in place. Cut a 1/2" (height) and 3/4" (width) notch in the front of connector (pipe, liner or adapter that will attach to flue outlet). Install connector into flue outlet and secure to angle brackets using machine screws. Seal around connection with furnace cement.

INSTALLATION

POSITIVE FLUE CONNECTION FOR MASONRY FIREPLACE

A Professional should inspect chimney prior to installation to determine if any repairs are necessary or if a chimney reline is necessary.

The fireplace damper must be secured in the open position. If this is not possible, it will be necessary to remove the damper. Installation into a masonry fireplace requires as a minimum of a flue extension past the header. This can be accomplished by one of the following methods:

Install 6" or 8" smoke pipe if the chimney is located directly above the insert flue

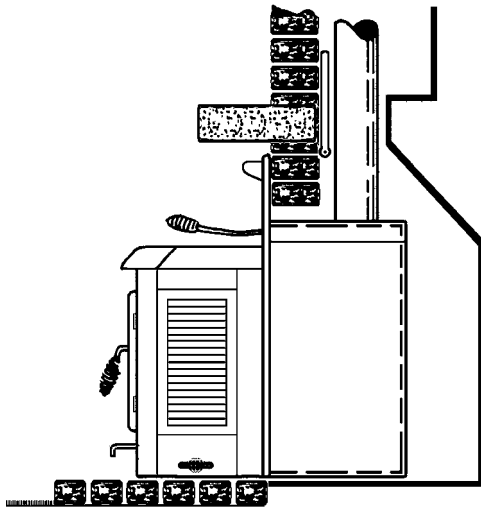

(Or) Install 6" or 8" flex pipe to achieve the same result.

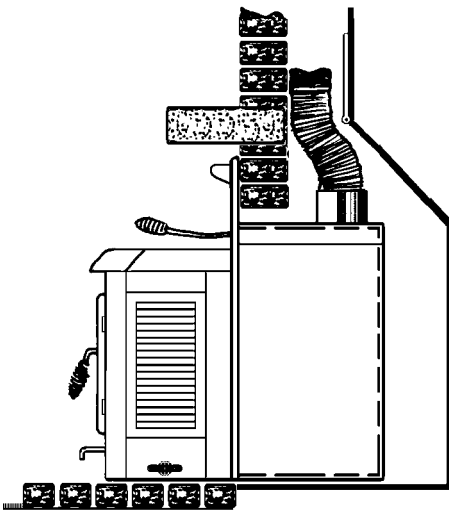

Use an offset adapter (see page 24) to handle offsets. This part is available through your dealer.

A preferable installation is the positive flue connection (a positive seal between the flue extension and the chimney). This can be achieved by using a filler plate. A filler plate can be made by making a cardboard pattern to fit the fireplace throat. Lay the pattern on 22 gage steel, add 2 inches to each side, and cut. Snip corners and bend front lip up and sides and back down. Cut an opening for the flue. Attach filler plate with masonry screws.

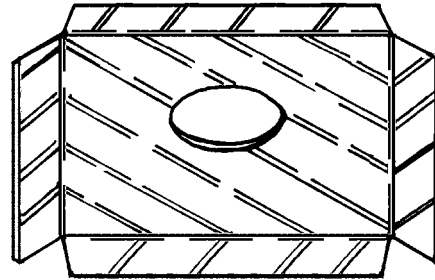

The starter pipe extends through the filler plate, past the damper and into the chimney system. Small air leaks should be sealed with high temp fiberglass or ceramic insulation.

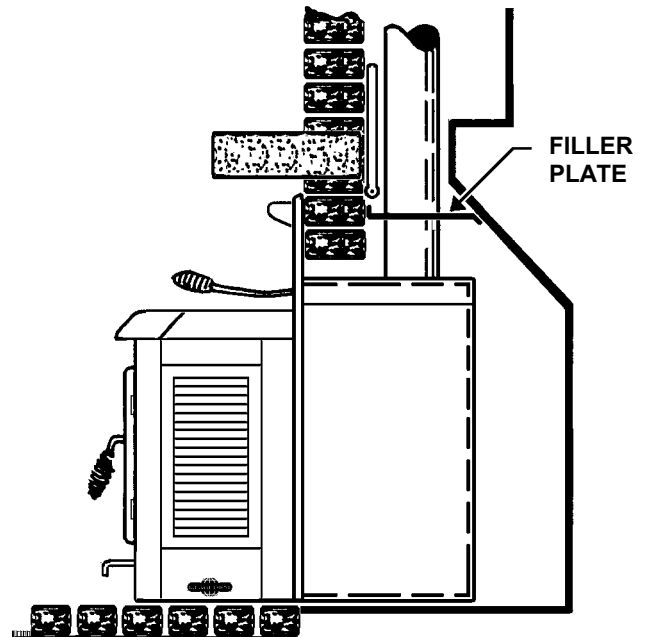

PRODUCT FEATURES AND CONTROLS

BLOWER SYSTEM

The 500-CFM room air circulation blower system comes equipped with a variable speed control (rheostat). The blower system can be operated manually or set to operate automatically (so the blowers will turn on when the insert is hot and turn off when the insert is cool). See Care and Operation Section – *Blower System* on page 14.

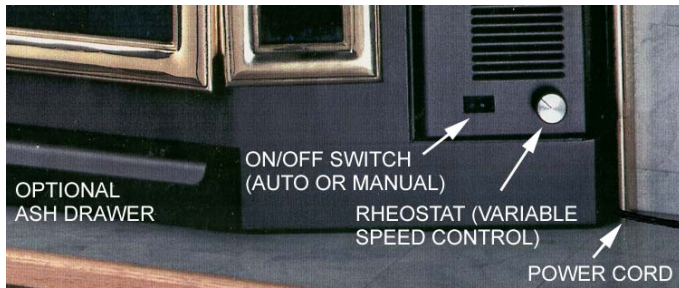

PRIMARY AIR CONTROL

The primary combustion air delivery is controlled by the primary air control draft module (The control handle is located above the fuel door). The heat output can be controlled by sliding the handle to a higher or lower heat output setting (see following illustrations). The fuel, the amount of heat and burn times desired, the type of installation are all variables that will affect the control setting. The same control settings in a variety of installations will produce different results. You will need to try different settings so you can learn how much heat to expect and how long the fire will burn.

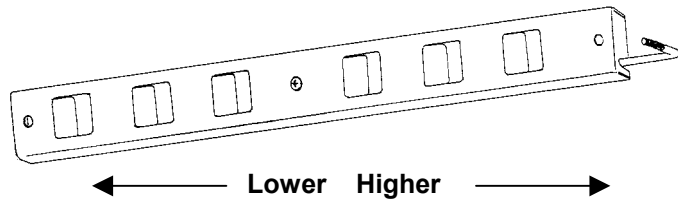

AIR AND DAMPER CONTROLS



CATALYTIC BYPASS DAMPER CONTROL

The bypass damper control handle is located on the front of the insert (see above illustration). By pushing in or pulling out the handle, the operator can route the exhaust either through the catalytic combustor (pushed in) or directly up the flue (pulled out). When starting a fire or refueling, the handle must be pulled out. Once the fire is established it must be pushed in.

CATALYTIC COMBUSTOR

How it works: From 5 to 30 percent of the chemical energy contained in every log escapes up the chimney when wood is burned in a conventional stove. The catalytic combustor is designed to make use of this energy, converting it into useful heat as it lessens chimney creosote build-up and air pollution. The catalytic combustor consists of a durable temperature resistant ceramic composition, which is extruded into a cellular, or honeycomb, configuration. After extrusion, this ceramic monolith is fired and then covered with a noble-metal catalyst. When wood smoke contacts this catalyst, chemical changes occur that causes the smoke to ignite at temperatures around 600° F. Normally, smoke will ignite and burn only at temperatures around 1000° F.

CARE AND OPERATION

FUEL DOOR

CAUTION: When opening the door, do not extend it beyond its normal travel. Overextending the door to a further open position can put excessive stress on hinge area of door and hinge pins and may result in breakage.

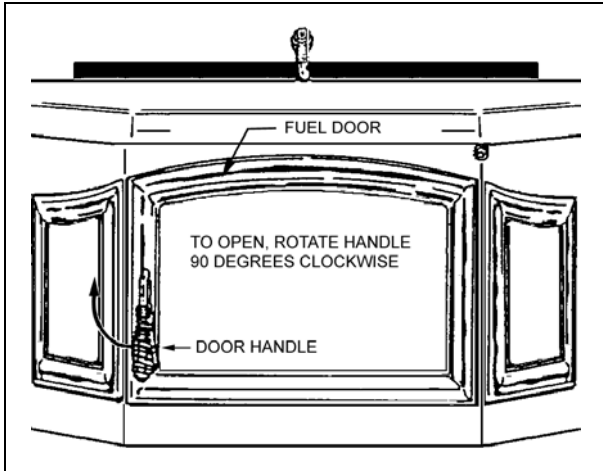

DOOR HANDLE ASSEMBLY

The door handle assembly opens and securely latches the fuel door closed. To open the door, rotate the coil handle to the 9:00 position until door releases. To close and latch, hold the coil handle in the 9:00 position, close the door, then rotate the handle to the 6:00 position. See illustration above.

GLASS

The Glass is a super heat resistant ceramic that withstands continuous temperatures up to 1390° F. This temperature is well beyond the temperatures in which you operate your fireplace insert.

This unit is designed to provide a flow of air over the inside of the glass, where along with high heat helps keep it clean. When operating the fireplace insert on low for extended periods of time, the glass may get dirty. A short, hot fire (15 - 20 minutes) will help clean off much of the normal buildup (see *Troubleshooting*). A commercial glass cleaner designed for fireplace inserts is recommended for cleaning.

The glass should be cleaned thoroughly with glass cleaner and a soft cloth BEFORE the fireplace insert is burned.

DOOR GASKET

The door gasket must be kept in good condition. Do not leave the stove burning with the door ajar or open. Leaving the door ajar or open while the stove is burning will cause excessive heat build up in the stove (overfiring) and could ignite surrounding combustibles as well as damage the stove (such damage is not covered by the manufacturers warranty).

USE CONTROL SETTINGS THAT WORK FOR YOU

The fuel, the amount of heat you want, the type of installation you have and how long you wish the fire to burn are all variables that will affect the control setting. The same control settings in a variety of installations will produce different results.

Familiarize yourself with your fireplace insert by trying different settings so you can learn how much heat to expect and how long the fire will burn. It may take a week or two to learn but your patience will be rewarded by the warmth and pleasant satisfaction that only a wood fire can provide.

CARE AND OPERATION

BREAK-IN PERIOD

Your fireplace insert finish is a high temperature paint that requires time and temperature to completely cure. We recommend that you ventilate the house during the initial burns. The paint emits non-toxic odors during this process.

KEEP YOUR HOUSE WELL VENTILATED DURING THE CURING PROCESS TO PREVENT ACTIVATION OF YOUR HOME SMOKE DETECTOR.

The paint manufacturer recommends three burn cycles to cure the paint. The first two burns should be low heat, approximately 250°F., for 20 minutes each, using paper and light kindling.

After each 20-minute burn, allow the appliance to cool completely. The third burn should be at least medium high or about 450°F. for 45 - 60 minutes. The paint will become soft and emit non-toxic haze during these burns. Keep the area well ventilated.

As the paint cures it will become slightly lighter in color. Eventually the entire surface will become an even color. Once the paint has been softened and cooled two or three times, it will harden. Do not turn on a blower during the curing process. Do not place anything on the fireplace insert surface until the paint is completely cured. Do not attempt to repaint the fireplace insert until the paint is completely cured. If the surface later becomes stained or marred, it may be lightly sanded and touched up with spray paint from the same paint manufacturer (See Maintenance – Repainting a Stove). Paint is available at your local authorized Lennox Hearth Products dealer. Never attempt to paint a hot stove.

CATALYTIC COMBUSTOR

During the start-up of a cold stove, a medium to high firing rate must be maintained for about 20 minutes. The high firing rate will ensure that the stove, the flue, the catalyst, and the fuel are all stabilized at proper operating temperatures. Even though it's possible to have temperatures in the stove reach 600°F. within two or three minutes after the fire is started, do not set the primary air control lever to the "LOW" position until approximately twenty minutes have passed. Setting the primary air control on "LOW" too early could result in either the fire or the catalytic combustor going out.

At the end of a burn cycle, it's possible that the hot embers remaining might not provide sufficient fuel value for the catalyst to retain its minimum operating temperature of 600°F. During the refueling, we recommend that the stove be refired for about 10 minutes with the bypass open to ensure a good draw is established and that the catalyst reaches 600° F. The refiring will ensure sufficient temperatures and proper amounts of volatiles for the catalyst to operate properly.

When refueling a hot stove with the catalyst still operating, no refiring step is necessary. Just open the bypass, set the primary air control to high, open the door approximately 1/2 inch, and wait for about thirty seconds. Load the fuel, close the door, close the bypass and set the primary air control to normal operation. Temperatures within the firebox should be hot enough to maintain the catalytic operation.

HOW TO START AND MAINTAIN A FIRE

1. (If optional ash drawer is installed) Check to ensure the ash dump cover (in center of firebox floor) is in place and the ash drawer is closed.
2. Open the bypass damper control by pulling it toward you. In the "OPEN" position the draft air will bypass the catalytic combustor and make starting the fire easier.
3. Set the primary air control lever on "HIGH". The "HIGH" setting will maximize your primary combustion air.
4. Build a fire directly on the firebrick covering the bottom of the stove.
 - a. Place five or six loosely crumpled sheets of newspaper in the stove.
 - b. Add a small amount of dry kindling randomly on the top of the newspaper.
 - c. Place a few more loosely crumpled newspapers on top of the kindling and light the bottom paper first, then light the top paper.
5. Once the kindling is ignited and burning on its own, close the fuel door. The upper fire should help preheat the chimney and create an effective draft while the lower fire ignites the kindling.
6. When the kindling is burning well, add increasingly larger pieces of wood until the fire is actively burning.
7. When the fire is well established, use the damper hook and close the bypass by pushing the control rod in (catalytic temperature probe should read 500-600°F, takes approximately 20 - 25 minutes to reach this temperature).
8. When the fire is well-established slide the air control lever for the desired heat output.

REFUELING

To refuel the stove, open the bypass and move the primary air control to "HIGH". Let the fire "LIVEN UP" for about one minute. Open the fuel door about 1/2" and hold in this position about 30 seconds or until the stove is drafting well. Open the door and add wood. After refueling, reset the primary draft control to the desired position, and close the bypass when the catalytic temperature probe reaches operating temperatures.

CARE AND OPERATION

BLOWER SYSTEM

The Blower System consists of a ON/OFF rocker switch, a variable speed blower speed control switch (rheostat), a thermally activated switch (fan disc) and 4 axial blowers.

When starting a fire, leave the blower system off until the insert is thoroughly heated (approx. 30 minutes after start up).

The blowers can be operated in one of the following manners:

AUTO: Turn Rocker Switch to the OFF "o" position and the rheostat to the ON position (rotate rheostat dial clockwise until it clicks). When the insert warms up (110° F), the blower will automatically turn on (adjust rheostat dial to the desired speed setting). When the insert cools down (90° F), the blowers will automatically turn off.

MANUAL: Turn Rocker Switch to the ON "-" position and adjust rheostat dial to the desired speed. The Blower will have to be manually turned off by rotating the rheostat dial counterclockwise until it clicks.

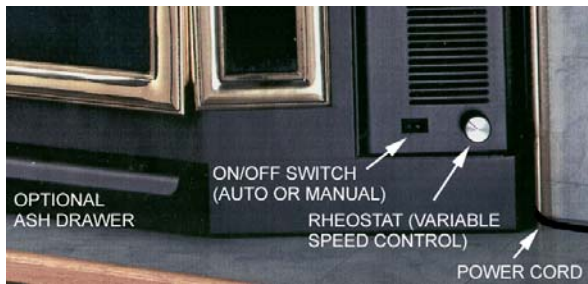

CAUTION: Burning the insert at a high burn rate for extended periods without running the blowers can cause excessive temperatures resulting in overfiring damage to the appliance. Overfiring damage is not covered under the 5 year prorated warranty.

WARNING: This appliance is equipped with a blower system which has a flexible electrical power cord with a three-prong (grounding) plug for your protection against shock hazard and should be plugged directly into a properly grounded three-prong receptacle per local codes or NEC, ANSI/NFPA 70-latest edition. Do not cut or remove the grounding prong from the power cord plug.

BLOWER SPECIFICATIONS: 115 Volt, 60 Hz, 4 axial blowers - .42 amps each, 125 CFM each (500 CFM total). Blower system has a flexible electrical cord that must be electrically grounded per local codes or NEC, ANSI/NFPA 70-latest edition. Do not route the power cord under or in front of the appliance.

POWER FLOW DIAGRAM

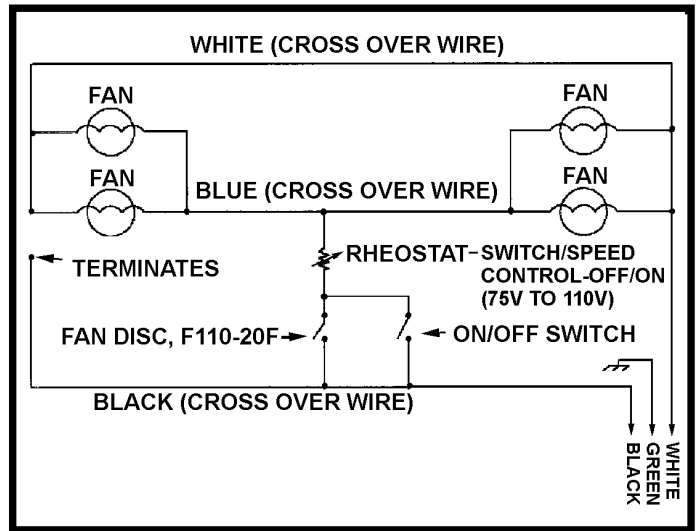

WIRING DIAGRAM

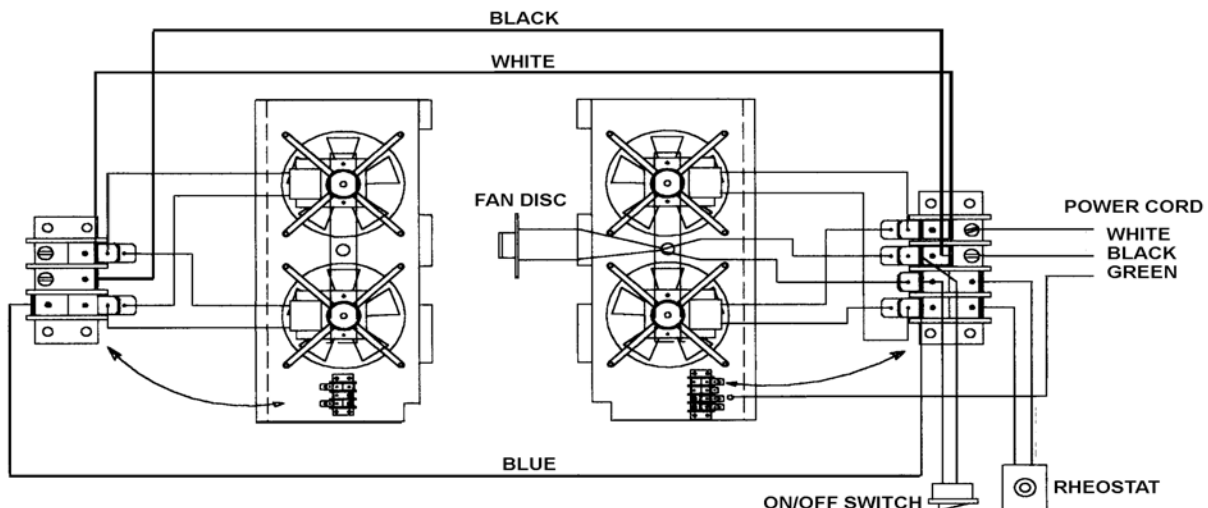

MAINTENANCE

BURN RECOMMENDED FUEL

This appliance is approved for use with natural dry wood only. Burning materials other than natural wood will shorten the life of the catalytic combustor. Do not burn particleboard or pressed logs using bonding agents as they can produce conditions which will deteriorate metal or damage the catalyst. Green or uncured wood does not work well as fuel, and can cause increased creosote buildups and plugging of the catalytic combustor. The value of green wood as a source of heat is limited. Do not overload or use kindling wood or mill ends for primary fuel as this may cause overfiring. Overfiring is a condition where excessive temperatures are reached, beyond the design capabilities of the fireplace insert. The damage that occurs from overfiring is not covered under the fireplace insert warranty.

WHY SEASON WOOD?

The key to the success of a good fire that produces heat from a wood burning insert is the wood. It needs to be well-seasoned natural wood.

What does "Well-Seasoned" mean?

When a tree is cut down, the wood is green, full of sap and moisture. This moisture content can exceed 80%, which must be reduced to less than 20%. Wood properly seasoned is then capable of generating the heat the fireplace insert was designed to provide.

Green wood does not burn easily. Attempting to burn green wood often results in a lot of smoke and very little fire. Time is the most important factor in seasoning wood. Ideally the moisture content should be reduced to 11-20%, although very few of us will be able to check that figure. There are several steps that should be taken to ensure that that you come close to these figures.

SEASONING GUIDE

Softwoods – 6 months to 18 months
Hardwoods – 12 months to 24 months

Logs that are 5" diameter across or larger should be split in half, three pieces if over 8 inches, and four pieces when over a foot across. If the tree was fell 2 to 4 years ago, it still needs to be cut, split, and seasoned for 6 to 24 months depending on the wood.

WOOD STORAGE

Wood to be seasoned should be stacked in an area open enough to ensure good air circulation on both sides – leaving adequate space between woodpiles to walk comfortable. Do not stack wood against a wall or building. It helps to elevate the woodpiles off the ground (two 2 x 4's running lengthwise beneath the woodpile works well). This allows air to flow under the bottom logs.

Wood that is kept outdoors, either covered with a tarp, or not covered at all, will not burn well until it has been in an enclosed space for one to two months.

SMALL AREA PAINT TOUCH-UP

The stove body is painted with a quality high-temperature stove paint. Use only model TSPK-B Stove Paint, Catalog # 70K99. Do not touch-up your stove with any other paint.

Using one small piece of 320 grit sand paper and lightly sand the blemish so that the edges are "feathered" or smooth to the touch between the painted and bare surfaces. Do not let the sand paper gum up with paint, as this will cause scratches on the metal surface. If there are any scratches, use 600 grit sandpaper instead. Mask off surfaces you do not want painted. Paint lightly over the bare surface first as this will act as an undercoat. Then paint over a larger area in smooth even strokes to blend.

See Break-In Period on page 13 for information on curing the paint.

FIREBRICK

The firebrick should be inspected periodically and replaced if damaged (crumbling or excessively cracked).

ASH REMOVAL AND DISPOSAL

CAUTION: Make sure that the fire is out and the stove is cold before removing ashes! (If optional ash drawer is installed) Never burn your stove with the ash dump cover off!

Ashes can hold live embers for several days, and must be disposed of with care.

(If the optional ash drawer is installed) Scrape ashes from the firebox through ash dump opening into ash drawer. After emptying, clean and replace the ash drawer.

NEVER place ashes in a cardboard box or any other combustible receptacle.

Proper Disposal of Ashes:

Ashes should be placed in a metal container with a tight fitting lid. The closed container of ashes should be placed on a noncombustible floor or on the ground, well away from all combustible materials, pending final disposal. If the ashes are disposed of by burial in soil or other wise locally dispersed, they should be retained in the closed container until all cinders have thoroughly cooled.

MAINTENANCE

DOOR / GLASS GASKET AND ASH DUMP GASKET

A 3/4" spun fiberglass gasket provides the seal around the fuel door and a flat spun fiberglass rope gasket (1/8" x 1") provides the seal around the glass. If the optional ash drawer is installed, a cerawool pad (4 1/4" x 8 3/8" x 1/2") provides the seal for the ash dump cover. Should these gaskets become frayed or damaged, they should be replaced with the same size and type as the original gasket. Contact your dealer for ordering. Use high temperature silicone sealer as an adhesive for replacing door and ash dump gaskets. The glass gasket has a self-adhesive backing.

WARNING: The gaskets must be kept in good condition. Do not leave the stove burning with the fuel door open or ash dump cover off. This will cause excessive heat build up in the unit and could ignite surrounding combustibles as well as damage the stove by overfiring it. Overfiring is a condition where excessive temperatures are reached, beyond the design capabilities of the stove (such damage is not covered by the manufacturer's warranty).

SERVICING GLASS

CAUTION: Be careful not to abuse door assembly by striking or slamming it. If the door assembly or glass is broken or damaged, they must be replaced before heater can be safely operated. Use only components provided by the manufacturer as replacement parts. Cleaning Glass: Ensure stove is cold prior to cleaning glass. A commercial glass cleaner designed for stoves is recommended. Do not use abrasive cleaners.

Replacing Glass:

1. Remove door from stove by lifting door up and off hinge pins: Place the door on a flat protected (towel) clean flat surface with the inside of the door facing up. Remove the glass clips (by removing screws holding clips), then carefully remove broken glass one piece at a time (protective gloves are recommended).
2. Clean area where the glass with gasket will be installed.
3. Install new glass with gasket (use only factory 5-mm glass with glass channel gasket. Do not substitute). Carefully reinstall glass clips. Be very careful not to overtighten screws.
4. Reinstall door.

CREOSOTE FORMATION AND NEED FOR REMOVAL

What is Creosote - When wood is burned slowly, it produces tar and other organic vapors, which combine with expelled moisture to form creosote. The creosote vapors condense in the relatively cool chimney flue of a slow-burning fire. As a result, creosote residue accumulates on the flue lining. When ignited this creosote makes an extremely hot fire. Also, creosote deposits tend to form in long runs of venting where gases become too cool prior to exhausting. Note: Single wall pipe cools rapidly, there-

fore installations using this type of flue are more susceptible to creosote deposits.

To inhibit the build up of creosote, adjust the primary air control to a medium-high or high setting for a 10-minute period each day. Do not attempt to burn out heavy creosote accumulations in this manner. This must be removed from the chimney by scraping or brushing to reduce the risk of a chimney fire.

Burn Approved Fuel Only - This stove is approved for burning dry seasoned natural wood only. Using green or inadequately seasoned wood may increase creosote buildup.

Inspection Frequency - The chimney connector and chimney should be inspected at least twice monthly during the heating season to determine if a creosote buildup has occurred. If creosote has accumulated it should be removed to reduce the risk of a chimney fire.

Cleaning - Remove the catalytic combustor and open the bypass damper prior to having your chimney cleaned (should be done by a qualified chimney sweep). See Maintenance, *Catalytic Combustor*, on page 17 for instructions on removing catalytic combustor.

IMPORTANT: Make sure the bypass damper is in the open position prior to chimney cleaning.

In the event of a chimney fire - Make sure the fuel door is securely closed. Adjust the primary air control to the lowest (most closed) setting. Call the fire department immediately. After a chimney fire, the complete chimney system should be checked by a qualified technician before further use.

Consult your dealer for suggestions on proper chimney care. Contact your local municipal or provincial fire authority for information on how to handle a chimney fire. Have a clearly understood plan for handling a chimney fire.

CATALYST REPLACEMENT

The normal expected life of a catalytic combustor is 10,000 to 12,000 hours (if appliance is operated correctly and proper fuels are used). If the catalyst has been deactivated, it should be replaced. Symptoms of deactivation include – noticeably darker smoke exiting chimney and less heat output. If these symptoms remain after normal maintenance or a major cleaning (soak in heated vinegar / water solution, see page 17), the catalyst probably needs replacement. Also, if the catalyst is broken and/or missing large pieces, it should be replaced.

Note: The catalyst does not need to be glowing to be working. It will glow at times, but it can work very effectively at temperatures well below the 1000° F level at which it will begin to glow.

MAINTENANCE

CLEANING BLOWERS

The blowers require inspection and cleaning annually to remove lint, dust, etc. If there are pets in the dwelling, the blowers should be cleaned at least twice a year. To access, remove blower covers (remove the two 1/4" hex head screws on each panel), then inspect propellers (replace if cracked or broken) and vacuum out lint, dust, and debris.

CATALYTIC COMBUSTOR

This appliance has been designed with a catalytic combustor, which will improve its overall performance. Removing the combustor assembly for cleaning and reinstallation is simple and convenient. Cleaning the combustor helps reduce buildup of ash and retarding chemicals. To clean the combustor, a soft brush, vacuum cleaner, or pipe cleaner may be used.

Cleaning the combustor once a year, preferably when your flue system is serviced, is sufficient for most users. Reinstall the combustor according to the following instructions.

The catalytic activity and effectiveness of a two to three year old combustor can be improved by following this Major Cleaning Procedure - Soak the combustor in a hot cleaning solution of a 50/50 mixture of white vinegar and distilled water for 30 minutes. Then rinse by soaking in hot distilled water. After 15 minutes, remove the combustor from the rinse water and gently shake out excess water. It is unlikely that you will notice a visible difference in the combustor after this cleaning procedure. The combustor unit is fragile in comparison to the rest of the stove, so handle with care.

1. Place the combustor on the tunnel baffle as shown in illustration (ceramic honeycomb to the back and louvered slots to the front). Push it back into the tunnel baffle until it hits the positioning stops. Make sure it is sitting flat against the bottom and the sides so that it does not tilt forward and jump the positioning stops.
2. Position combustor clip over the middle of the secondary air tube as illustrated. Make sure that one of the holes in the secondary air tube is centered in the 1/2" hole on the clip. You can feel with your fingertip.
3. Tighten screw snugly, but do not over-tighten or you may spread the clip apart.

REMOVING COMBUSTOR CLIP

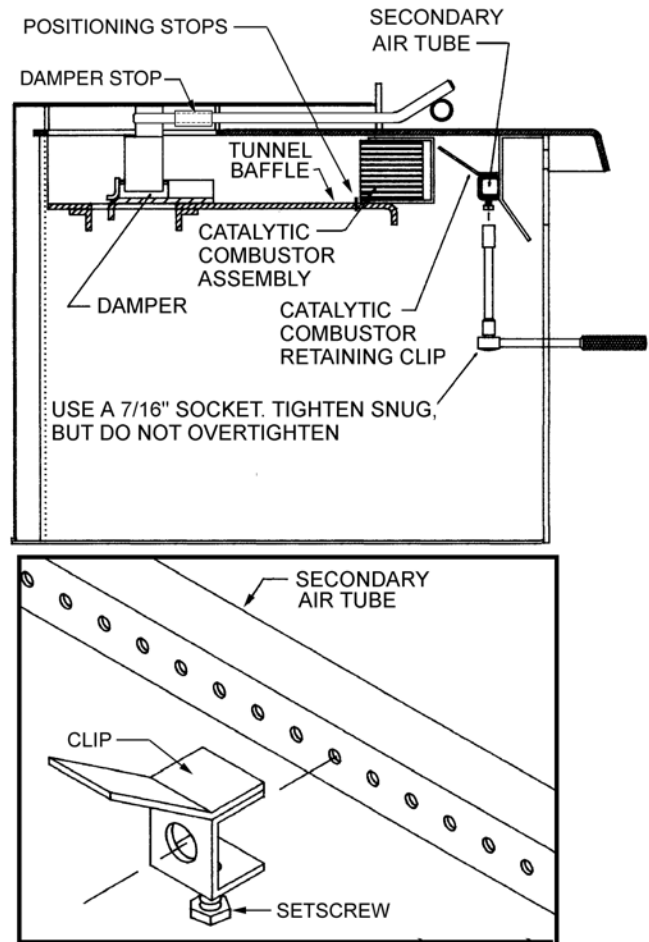

TROUBLESHOOTING

* **SMOKES OUT FUEL DOOR WHEN OPEN**

1. The primary air control is closed.
2. The chimney is too cool. Set the primary air control on "HIGH" with the bypass damper control "OPEN" for a few minutes before opening the fuel door.
3. Excess creosote will not only restrict your draft but it will create a risk of a creosote fire. Strictly adhere to maintenance requirements as outlined in this manual. If excess creosote has built up on the inside of the firebox sides and door, burn a small hot fire at intervals that are more frequent with air control on HIGH for a few minutes.
4. Deposits may have built up in the chimney and are restricting the draft, or the spark arrester on top of the chimney may be plugged.
5. Chimney diameter too large or too small to provide adequate draft.
6. The house is too airtight (usually takes 20 to 30 minutes for problem to appear as stove lowers air pressure in house). Crack a window open or provide an outside source of air near stove.
7. Insufficient vertical height to chimney to achieve adequate draft.
8. The combustor is plugged from engaging too soon (remove combustor and clean, see Maintenance section).

* **DOES NOT PRODUCE ENOUGH HEAT**

1. Using green or insufficiently cured wood.
2. Excessive draft.
3. High ceilings (heat rises quickly, but can be recirculated by a well-placed ceiling fan with a winter/summer switch).
4. The area to heat, is too large (square foot heating estimates are based on "average" climates and home design.)
5. There's an obstruction in the chimney.
6. The chimney or chimney cap is restricted by creosote preventing enough draw to sustain a "HIGH" heat rate.
7. Combustor light off has not occurred.

* **DOES NOT MAINTAIN A FIRE**

1. Soft wood does not burn as long or as well as seasoned hardwood resulting in a short burn time.
2. Wood size too small. Burns at too rapid a rate.
3. The gasket seal on the fuel door, ash dump cover or glass is leaking air. Repair or replace it if necessary.
4. There is an obstruction in the chimney.
5. The stove was not up to normal operating temperature before the bypass damper control was pushed closed.
6. Excessive draft.

* **BACKPUFFING**

1. Downdraft in the chimney (may need a special wind cap).
2. The catalytic combustor is too hot (avoid burning soft, pitchy woods, or large amounts of small-diameter wood).
3. The house is too air tight (ventilation is needed).
4. Insufficient vertical height to chimney to achieve adequate draft.

ODORS

1. Creosote accumulation in firebox (brush out on next cleaning).
2. Chimney downdraft when stove is not operating (close primary air control).
3. Catalytic combustor not functioning.
4. Paint curing on first several burns.

* **DIRTY GLASS**

1. Poor draft conditions.
2. Long burn periods at low draft settings.
3. Burning wet, pitchy or spongy wood.
4. Poorly arranged logs (too close to glass).

- * **Draft problems; If installing into a larger flue, it may be necessary to use a full length liner to achieve adequate draft for the appliance. A draft gauge should read a minimum of .05" W.C. (inches water column) not to exceed .07" W.C. for optimum performance (see *Draft Requirements*).**

TROUBLESHOOTING

OVERFIRING

If any part of the appliance glows, it is overfiring. Other symptoms may include: Cracking, warping or burning out of components, catalytic combustor may deteriorate, gold doors may turn color, stove glass may develop a haze which will not come off with cleaning, firebox baffle plate (tunnel baffle) may warp, etc.

Overfiring of a fireplace insert is a condition where excessive temperatures are reached, beyond the design capabilities of the appliance (as outlined the following 4 paragraphs). The damage that occurs from overfiring is not covered under the manufacturer's limited warranty. The following are a few conditions that should be evaluated and (corrected if necessary) if an overfiring condition is suspected:

Overfiring Caused From Improper Installation

The venting system must satisfy the draft Requirements of the appliance. The appliance is merely one component of a larger system. The other equally important component is the venting system, which is necessary for achieving the required flow of combustion air to the fire chamber and for safely removing unwanted combustion byproducts from the appliance. If the venting system's design does not promote these ends, the system may not function properly, which may create performance problems as well as may be a safety hazard. To ensure that all installation requirements have been met as outlined in the installation manual. The chimney should be clean and in good repair. A draft test should be performed to determine if the draft requirements of the appliance are being met. A draft gauge should read between .05 and .07 inches water column (W.C.I.). Excessive draft (above .07 W.C.I.) will allow too much combustion air to be pulled into the firebox, which results in hotter burns. Too little draft (below .05 W.C.I.) will not allow enough combustion air delivery to maintain a fire well or cause performance problems such as smoking (this may result in improper operation of appliance, i.e. will not maintain fire well unless catalytic bypass is left open, or with fuel door left open – see Overfiring Caused From Improper Operation).

Overfiring Caused From Improper Operation

Never burn the appliance with the fuel door open or ajar, the ash dump cover off or the ash drawer open (if optional ash drawer is installed). Never burn the stove with the bypass handle in the open position once the fire has been established or the air control in the "high" position for extended periods.

Overfiring Caused From Improper Maintenance

Strictly adhere to all maintenance requirements at frequent intervals as prescribed in this manual including cleaning of flue and fireplace insert. Should the fuel door, ash dump (if optional ash drawer is installed) or glass gaskets become worn or damaged, they should be replaced.

Overfiring Caused From Improper Fuel

This appliance is approved for use with natural dry well seasoned wood only (consult your dealer for approved fuels in your area). Do not burn garbage, particleboard scraps, or pressed logs using bonding agents because they can produce conditions that will deteriorate metal. Green or uncured wood does not work well as fuel, and can cause increased creosote buildups. Do not overload or use kindling wood or mill ends as primary fuel.

SPECIFICATIONS - Model BV400C-2

Maximum log length	24"
Flue size	8"
Width w/standard surround	48"
Width at fireplace opening	29 1/2"
Width at rear of firebox	21 1/2"
Depth into Fireplace	15 3/4"
Depth (overall)	26 1/4"
Height *	20"
Height w/standard surround	32"
Add 3 1/2" to height when optional ash drawer is installed	

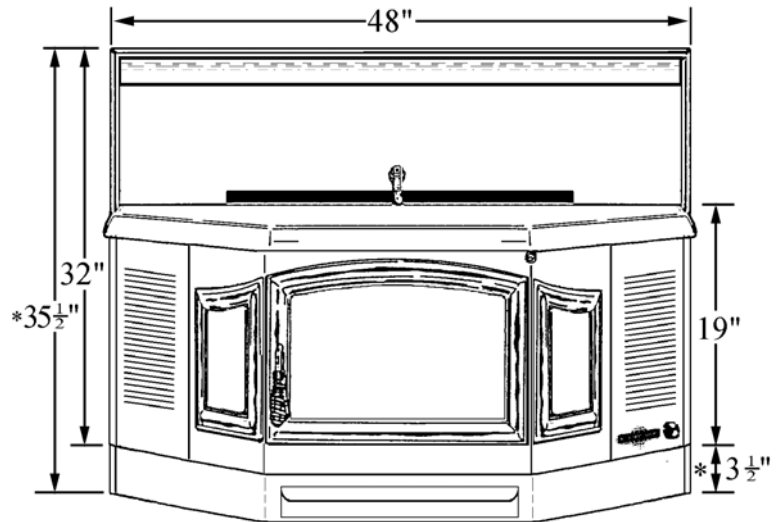

* SHOWN WITH OPTIONAL ASH DRAWER INSTALLED

Back of Stove to Center of Flue 6"

Approximate burn time 8 - 12 hours

Approximate Fuel capacity 80 lbs.

Firebox size (cubic feet) 3.72 c.f.

Maximum Burn Rate (BTU) 66,805

EPA BTU Range 11,000-48,100 BTU

EPA Efficiency 72%

Emissions Rate (grams/hour) 3.0 gph

Approximate weight with brick 455 lbs.

Air Control Manual

Blower Assemblies (Standard) 500 cfm
(Comes standard with - 4 blowers, 125 cfm each, heat activation switch, manual or auto-control with variable speed rheostat)

Dimensions shown are approximations only (+/- 1/4")

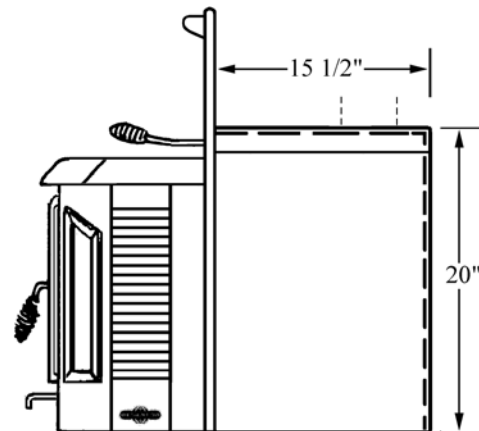
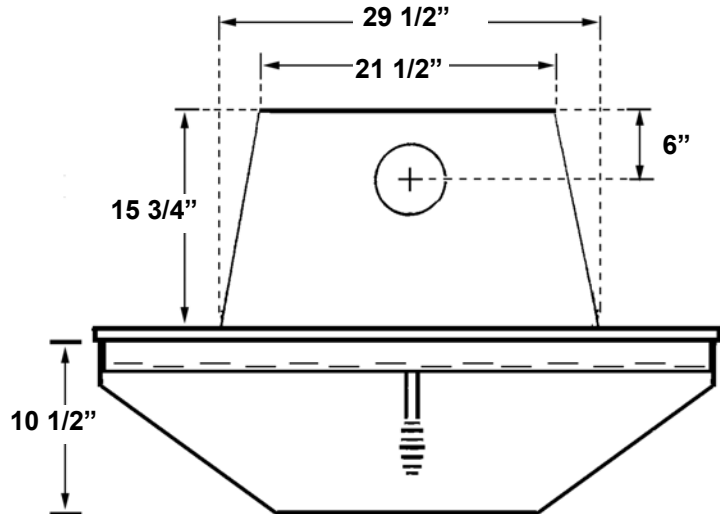

COMPONENT DIAGRAMS – Model BV400C-2

ITEM NO	DESCRIPTION
Door and Glass Parts	
27M67	Clip Set, Glass
H0537	Door Assembly, Gold (handle included)
86-128	Gasket Kit, 3/4" Door Rope (includes adhesive)
27M81	Gasket Kit, Door Glass (10' of 10580)
G400-7	Glass, Large Arched 11 x 17" (gasket not included)
G410	Glass, Side 4 x 8 3/4" (gasket not included. order 2 if set is needed)
LB-102214	Handle Assembly
11529	Hinge Pin 10 L 18 (Original) Requires Welding
11531	Hinge Pin, Retrofit (requires drill #3 [.213"] & Tap 1/4"-28 UNF. order 2 if set is needed)
10362	Torque Plate (Latch)
11538	Trim, Left Side Gold
11540	Trim, Right Side Gold
Draft Module Parts	
907	Handle, Draft Module Coil
26M68	Module Assembly, Draft (controls burn rate)
Catalytic Combustor Parts	
11000	Clip, Combustor
ESCC	Combustor Assembly 2" (*SN<7802) - Includes ceramics, gasket & housing
14000	Combustor Assembly 3" (*SN>7802) - Includes ceramics, gasket & housing
BV100	Probe, Combustor Temperature
11485	Housing, Combustor
11481H	Gasket, Interam Combustor (1/16"x3"x36")
Room Air Blower Parts	
410-25L	Blower Assembly, Left ♦
410-25R	Blower Assembly, Right ♦
11565	Disc, Low Limit (fan disc for blowers, F110°-20F, 60T12)
LB-102280	Wire Harness Kit (Includes Left Side Crossover Wire Harness, Right Side Wire Harness and Power Cord)
10050087	Knob, Rheostat
LB-101496	Motor, Blower, 1 ea. (includes metal propeller)
26M22	Power Cord (does not include power cord restraint, p/n 2062)
2062	Restraint, Power Cord
42M1401	Propeller, Metal Blower Motor
528	Rheostat, Blower Speed Control (knob not included)
410-270	Switch, On/Off (Bypass)
410-260	Terminal Block, Large
410-265	Terminal Block, Small
Surround Parts	
2046	Bracket, Surround Trim ("L" bracket / corner key. order 2 if set is needed) 02046
410-43	Insulation Kit Set, Surround
430	Surround Assembly, Standard 48" x 32"
430XL	Trim Kit, Gold Tone, 48" x 32" (standard)
26M69	Trim Kit, Gold Tone, 48" x 35 1/2" (taller side trim for units with optional ash drawer installed)
Miscellaneous Parts	
775005M	Manual, Installation and Operation (owners manual)

COMPONENT DIAGRAMS – Model BV400C-2

Firebox Parts	
11711	Cover, Ash Dump (w/ Gasket 4 1/4 x 8 3/8" x 1/2")
26M70	Damper Kit, Bypass (damper, linkage and rod)
LB-102215	Damper Stop (sleeve for damper rod to limit travel of damper door)
FB17	Firebrick, 3 1/4 x 5 1/8 x 0" Regular (order 2, if set is needed) ◇
FB16	Firebrick, 8 3/4 x 2 1/4 x 5 1/8" Regular (order 2, if set is needed) ◇
FB22	Firebrick, 9 x 3 1/4" Regular (order 2, if set is needed) ◇
FB-1	Firebrick, 9 x 4 1/2" Regular (order 8, if set is needed) ◇
FB-2	Firebrick, 9 x 4 1/2" w/ Notch (order 4, if set is needed) ◇
11812	Gasket, Ash Dump (4 1/4 x 8 3/8 x 1/2")
C-200-51	Hook, Damper (Coil handle with hook for opening / closing damper bypass)
◆ Blower assemblies include 2 blowers w/ propellers, mounting bracket and terminal block.	
◇ All firebrick are 1 1/4" thick	

FIREBRICK (All Brick are 1 1/4" THICK)

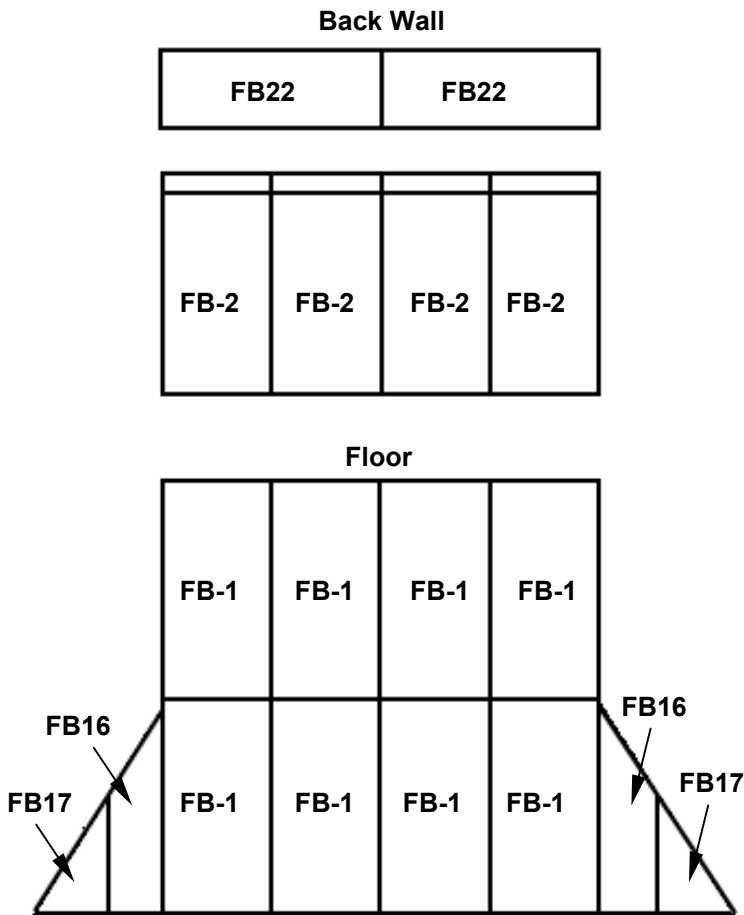

FIREBOX COMPONENTS

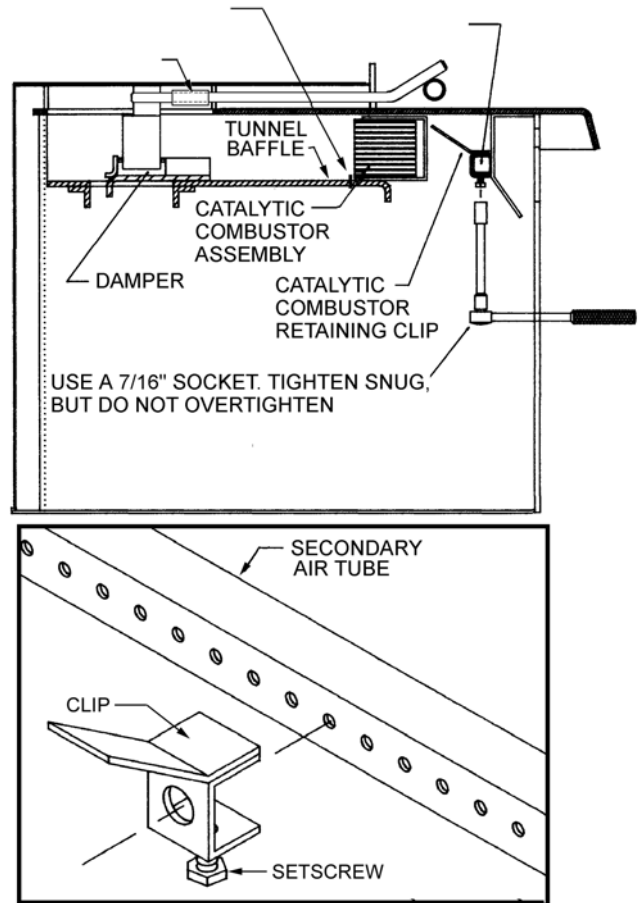

COMPONENT DIAGRAMS – Model BV400C-2

REPLACEMENT DAMPER KIT (Cat. No. 26M70)

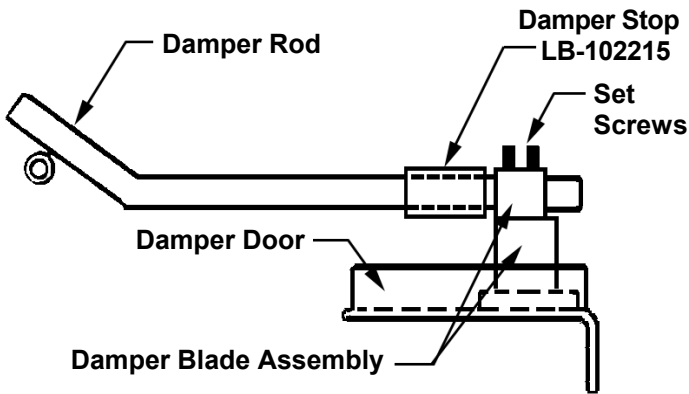

DOOR ASSEMBLY - Cat. No. H0537 (Gold) and Cat No. H0538 (Black) (Includes Handle Assembly, Not Shown)

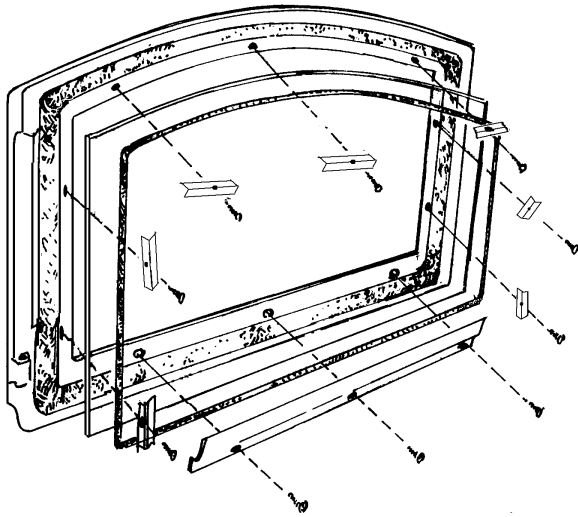

HANDLE ASSEMBLY (P/N LB-102214)

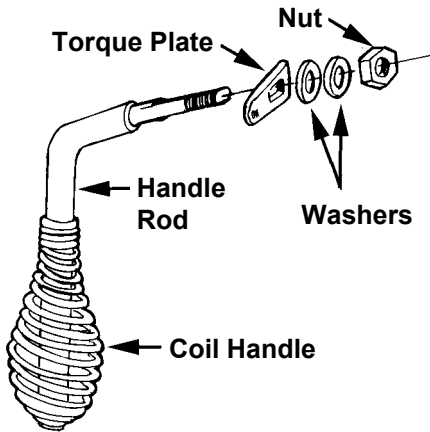

DRAFT MODULE ASSEMBLY (Cat. No. 26M68)

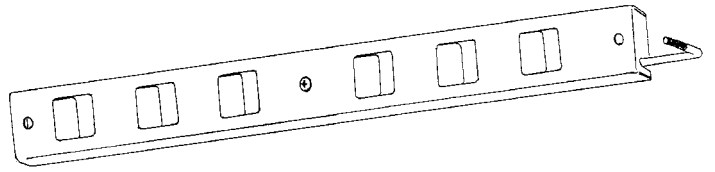

WIRE HARNESS KIT (P/N LB-102280)

Includes the following 3 Components:

Wire Harness – Right Side

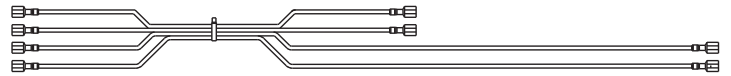

Wire Harness –Left Side (Crossover Wires To Left Side)

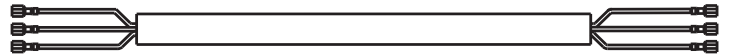

Replacement Power Cord

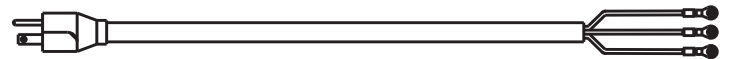

OPTIONAL ACCESSORIES - Model BV400C-2

Accessories

Part/ Cat. No.	Model	Description
14M69	AD-BV400C	Ash Drawer – Includes taller surround side trim-35 1/2" because ash drawer adds 3 1/2" to height of insert.
14M77	OA400-8	8" to 8" Offset Adapter for flue outlet.
14M79	OA400-86	8" to 6" Offset Adapter for flue outlet.
70K99	TSPK-B	Paint, Flat Metallic Black, 12 oz. Spray Can (stove/pipe paint)

OPTIONAL ASH DRAWER (Catalog # 14M69)

The optional ash drawer assembly installs underneath the appliance (it adds 3 1/2" to the height when installed). It is designed to make cleaning easier by containing the ashes in a removable drawer.

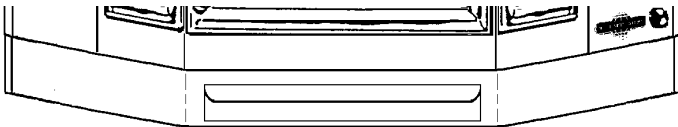

* OFFSET ADAPTERS

CAT NO. 14M77 (8" to 8" for Masonry Fireplaces) & 14M79 (8" to 6" for Factory Built Fireplaces) Installations requiring offsets can be handled using an offset adapter (it aligns starter pipe with flue).

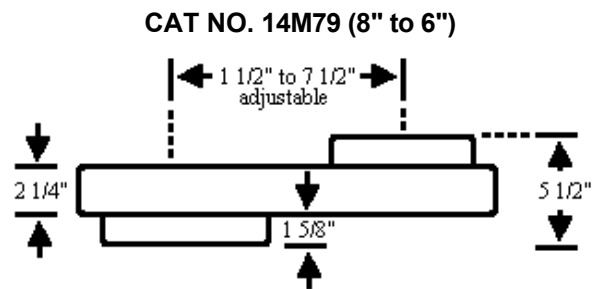
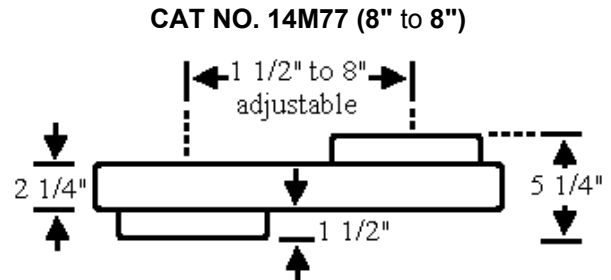

Actual Appearance

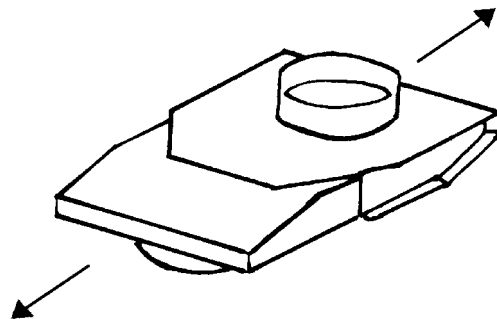

SAFETY / LISTING LABEL

CONTACT YOUR LOCAL BUILDING OR FIRE OFFICIALS ABOUT RESTRICTIONS AND INSTALLATION INSPECTION IN YOUR AREA

Listed Masonry Fireplace Accessory/Insert
FOR USE WITH SOLID FUEL ONLY



Manufactured by:
LENNOX HEARTH PRODUCTS
1110 West Taft Avenue
Orange, CA 92865

"PREVENT HOUSE FIRES"

Install and use only in accordance with manufacturer's installation and operating instructions and your local building codes. Do not connect this unit to a chimney flue serving another appliance.

NOTE: Replace glass only with 5mm ceramic.

ELECTRICAL MOTOR/RATING:
Aerovox, Model S10625082, 115V, .5 Watts, 60 Hz

DANGER: Risk of electrical shock. Disconnect power before servicing unit. Do not route power cord under or in front of appliance.

Approved for installation in listed zero-clearance fireplaces. Zero-clearance installations require a full reline from the flue collar to the rain cap. For flue collar offsets in Zero-clearance installations use only part #14M79. For flue collar offsets in a masonry fireplace use only part #14M77. See manual for further information.



SERIAL NO.

MODEL: BAYVIEW 400C-2
CAT. NO.: H0542
OREGON DESIGN NO: E.S.-05
TESTED TO: UL 1482
REPORT NO. 030-S-04-2

CATALYTIC COMBUSTOR: Burning of metal foils, coal, plastic, garbage, sulphur and diesel oil will make the catalyst in the converter inactive. The converter is fragile; handle carefully. The performance of the catalytic device or its durability has not been evaluated as part of the certification.

Minimum Clearances to Combustible Materials (in inches)

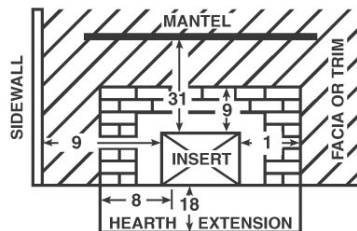

Install insert with a minimum of 9" clearance to combustible sidewall, 1" to side and 9" to top trim, 31" from top of insert to mantel. Floor protector must be 3/8" minimum non-combustible material or equivalent, extending 18" in front of insert and 8" to both sides. When used as an insert stove, install only in a masonry fireplace, built to UBC Chapter 37. Do not remove brick or mortar from masonry fireplace to accommodate insert. Use flue outlet

with a direct connector in a masonry chimney. Remove and clean behind unit frequently, as creosote buildup may occur rapidly.



CAUTION: HOT WHILE IN OPERATION. DO NOT TOUCH. CONTACT MAY CAUSE SKIN BURNS. KEEP FURNISHINGS AND COMBUSTIBLE MATERIAL A CONSIDERABLE DISTANCE AWAY. SEE NAMEPLATE AND INSTRUCTIONS. DO NOT OVERFIRE. IF HEATER OR CHIMNEY CONNECTOR GLOWS, YOU ARE OVERFIRING. INSPECT AND CLEAN CHIMNEY AND CONNECTOR FREQUENTLY. UNDER CERTAIN CONDITIONS OF USE, CREOSOTE BUILDUP MAY OCCUR RAPIDLY. DO NOT USE GRATE OR ELEVATE FIRE - BUILD WOOD FIRE DIRECTLY ON HEARTH. DO NOT BURN WITH FEED DOOR OR FLUE BYPASS OPEN. FEED DOOR MUST BE CLOSED DURING FIRING EXCEPT WHEN ADDING FUEL. OPEN FLUE DRAFT BEFORE OPENING FEED DOOR.

U.S. ENVIRONMENTAL PROTECTION AGENCY
Certified to comply with July 1990 particulate emission standards.

This wood heater contains a catalytic combustor, which needs periodic inspection and replacement for proper operation. Consult owner's manual for further information. It is against the law to operate this wood heater in a manner inconsistent with operating instructions in the owner's manual, or if the catalytic element is deactivated or removed.

DATE OF MANUFACTURE

2002 2003 2004 Jan. Feb. Mar. Apr. May June July Aug. Sept. Oct. Nov. Dec.

P/N 9-1443, Rev. NC DO NOT REMOVE THIS LABEL Made in U.S.A. IGN

Manufactured by Lennox Hearth Products

Model: Bayview 400C-2

US ENVIRONMENTAL PROTECTION AGENCY

CATALYST EQUIPPED

MEETS EPA PARTICULATE MATTER (SMOKE) CONTROL REQUIREMENTS FOR CATALYTIC WOOD HEATERS BUILT ON OR AFTER JULY 1, 1990. SEE CATALYST WARRANTY. ILLEGAL TO OPERATE WHEN CATALYST IS NOT WORKING. SEE OWNER'S MANUAL FOR OPERATION AND MAINTENANCE.

SMOKE

THIS MODEL



0 (Grams Per Hour) 5.5

EFFICIENCY*



50% 60% 70% 80% 90% 100%

Wood heaters with higher efficiencies cost less to operate.

*(NOT TESTED FOR EFFICIENCY. THE VALUE INDICATED IS FOR SIMILAR CATALYST-EQUIPPED WOOD HEATERS.)

HEAT OUTPUT 11,000 to 48,100 Btu/Hr

Use this to choose the right size appliance for your needs.
ASK DEALER FOR HELP

This wood heater will achieve low smoke output and high efficiency only if properly operated and maintained. See owner's manual.

OWNERSHIP RECORDS

Dealer's Name:

Dealer's Address:

City:

State:

Zip Code:

Serial Number:

Date of Purchase:

Date Installed:

Notes:

SERVICE AND MAINTENANCE LOG

Service Date	Service Technician	Service Description
--------------	--------------------	---------------------

--	--	--

--	--	--

--	--	--

--	--	--

--	--	--

--	--	--

--	--	--

--	--	--

--	--	--

--	--	--

--	--	--

--	--	--

--	--	--

--	--	--

--	--	--

--	--	--

--	--	--

LENNOX[®]

HEARTH PRODUCTS
1110 West Taft Avenue
Orange, CA 92865